

New Dimension



Staircase-Software Programs

Version CAD-ND Basis

Article no. 00119301



constructing/presenting

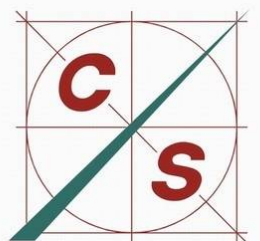

Compass Software

Software for staircase manufacturing

Version CAD-ND Basis

Ground plan / Ground plan standard

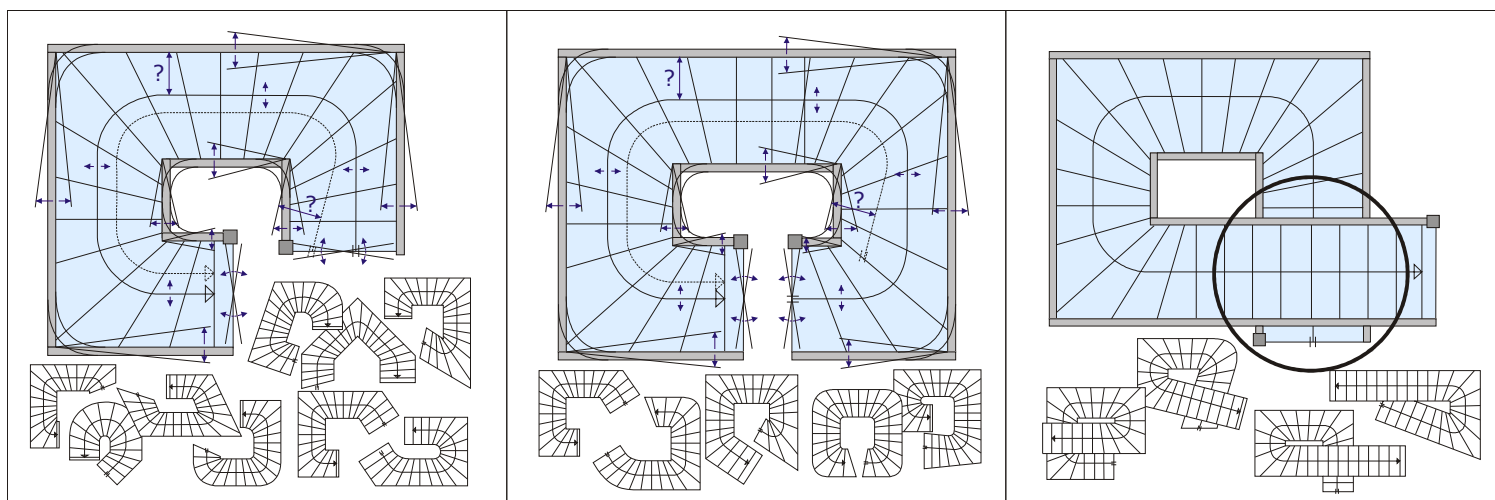
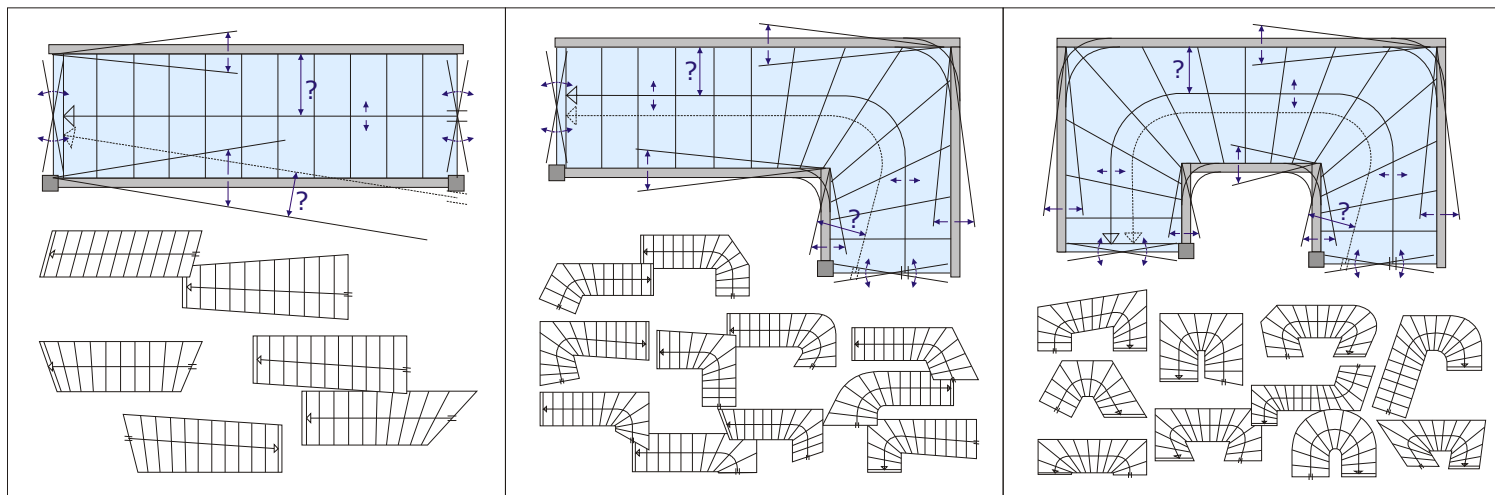

Ground plan / Ground plan freeform

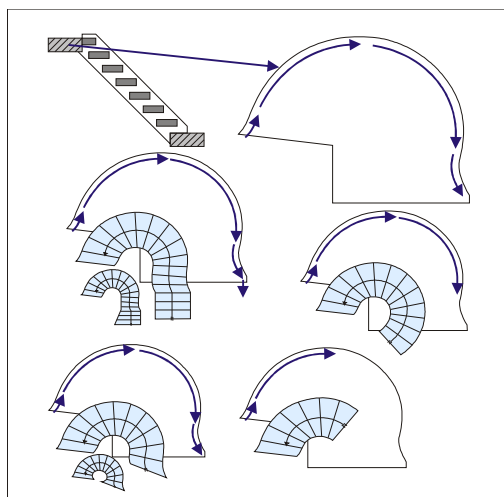

Version CAD-ND Basis

Ground plan / Type in corner

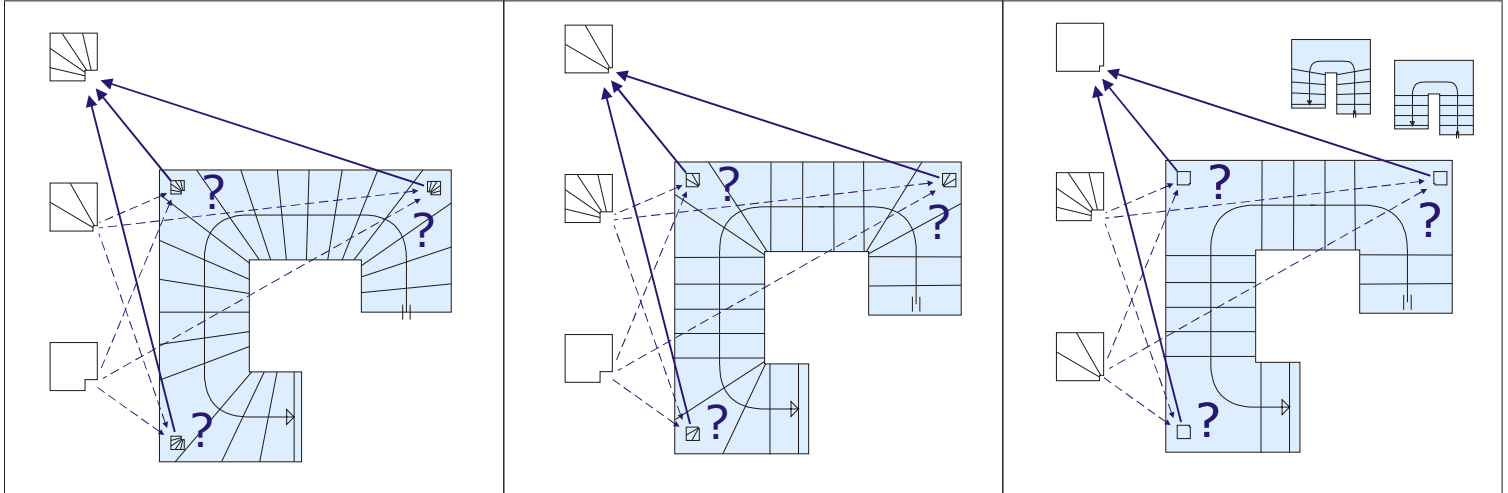

Ground plan / Details

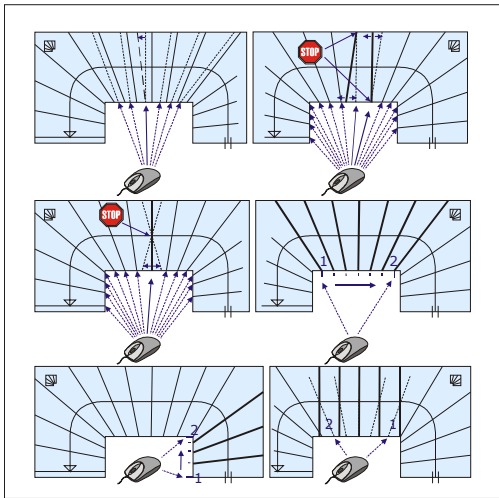

Ground plan / Output

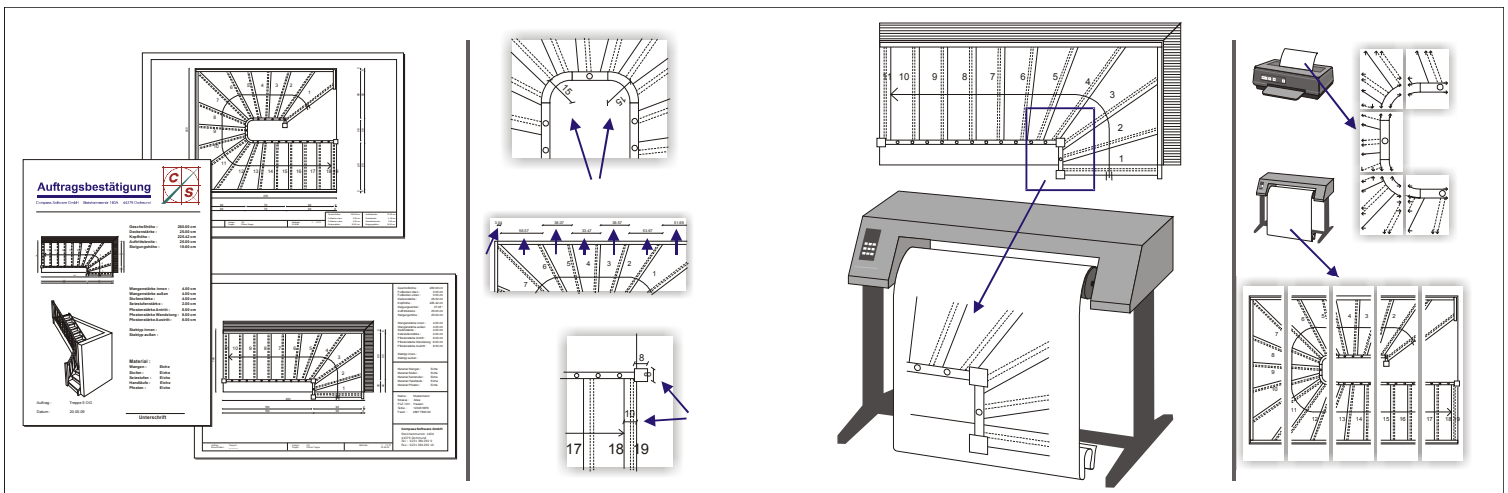

Version CAD-ND Basis

Walls / Walls

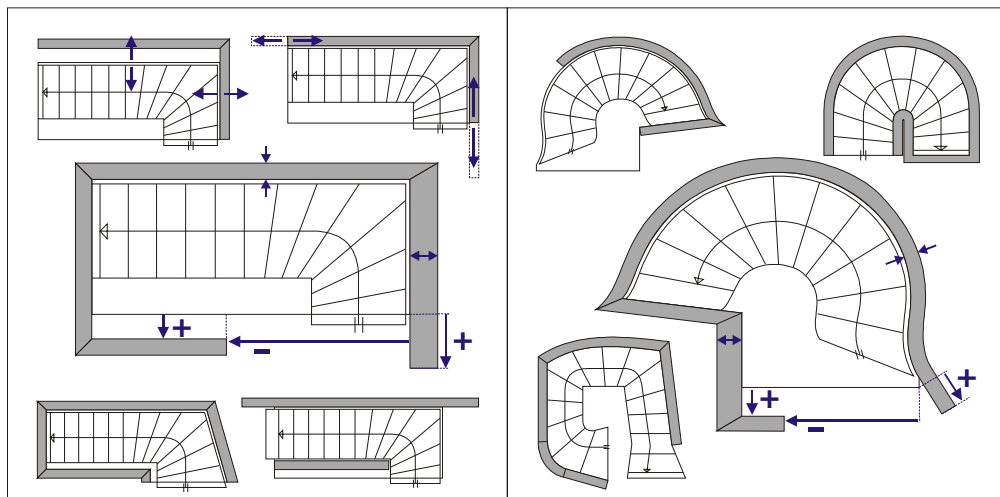

Walls / Windows

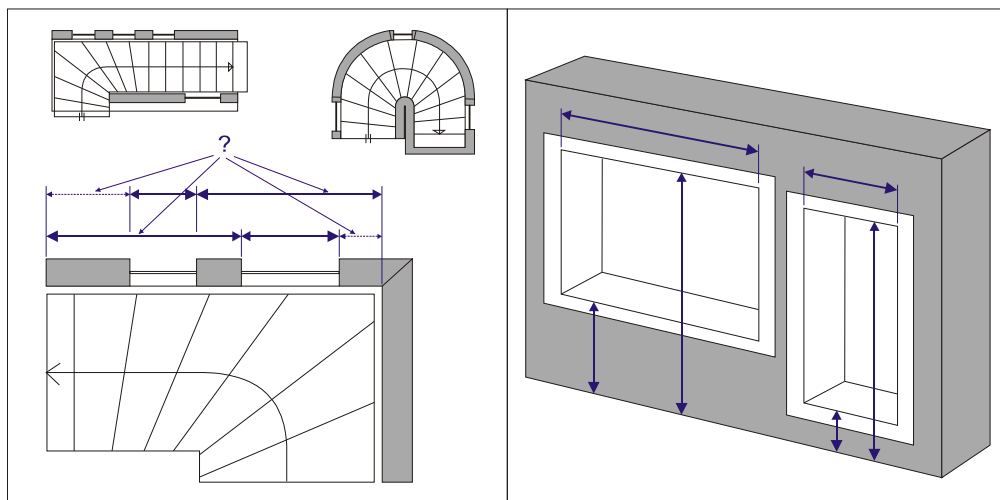

Walls / Doors

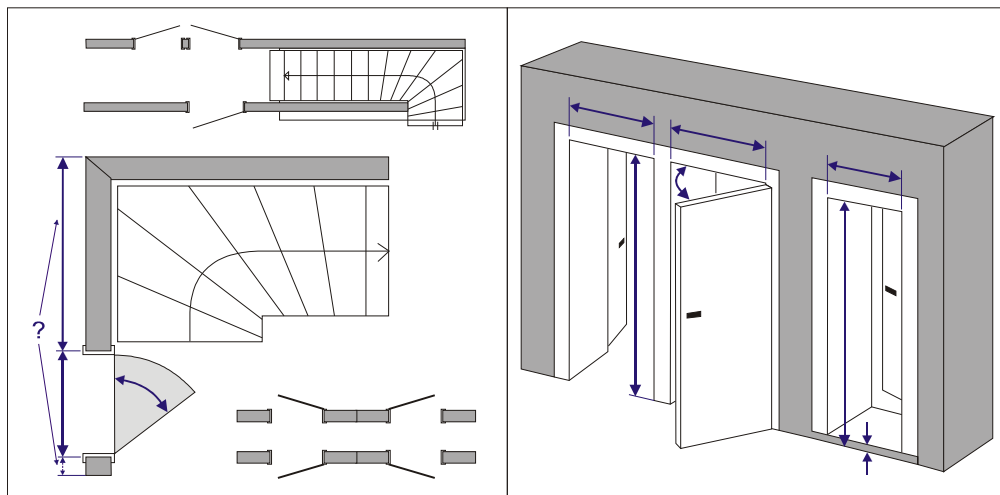

Version CAD-ND Basis

Walls / Wall opening

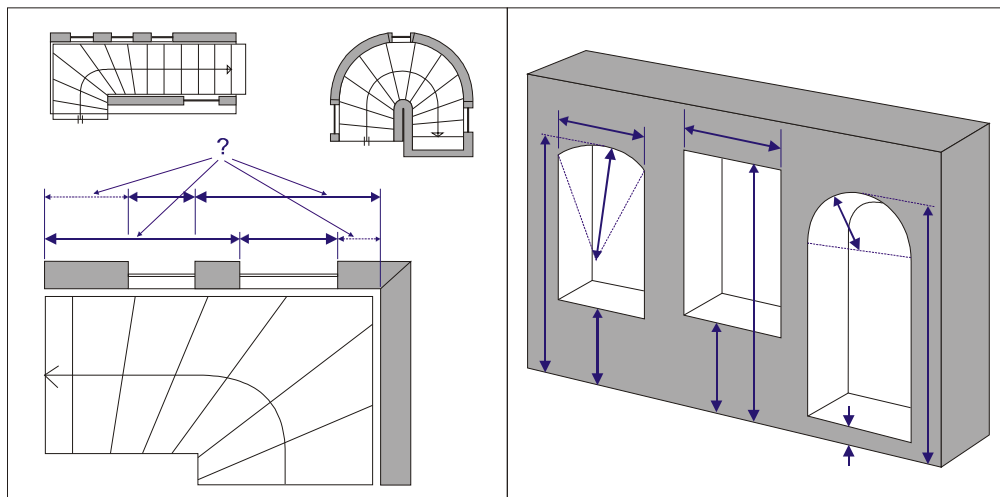

Walls / Output

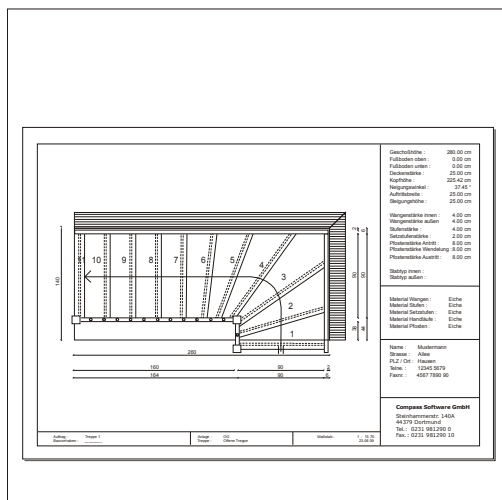

Treads / Type

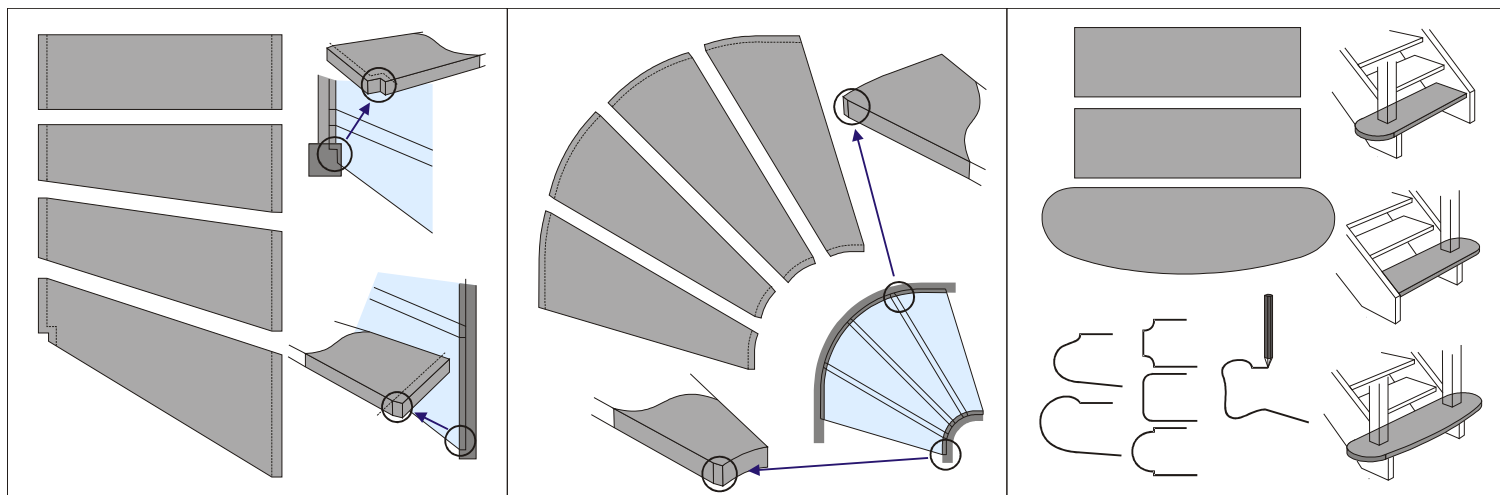

Version CAD-ND Basis

Treads / Details

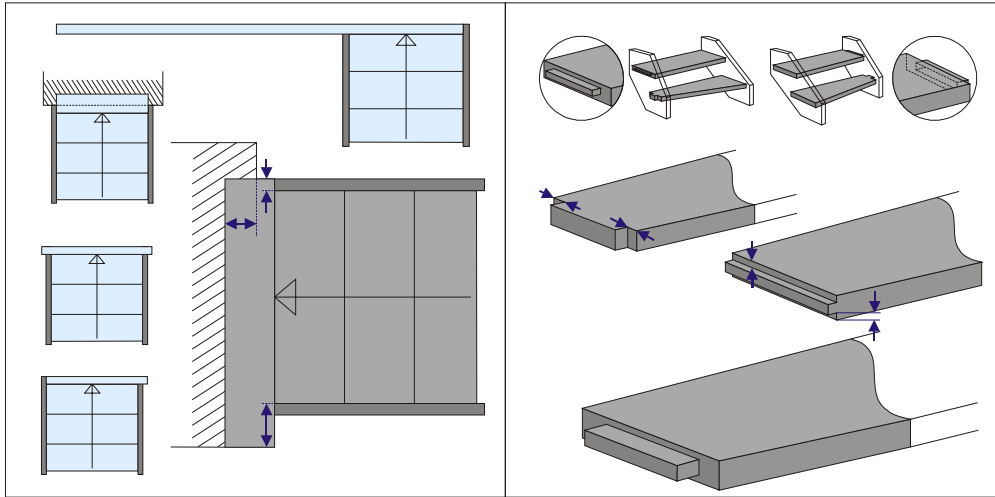

Treads / Output

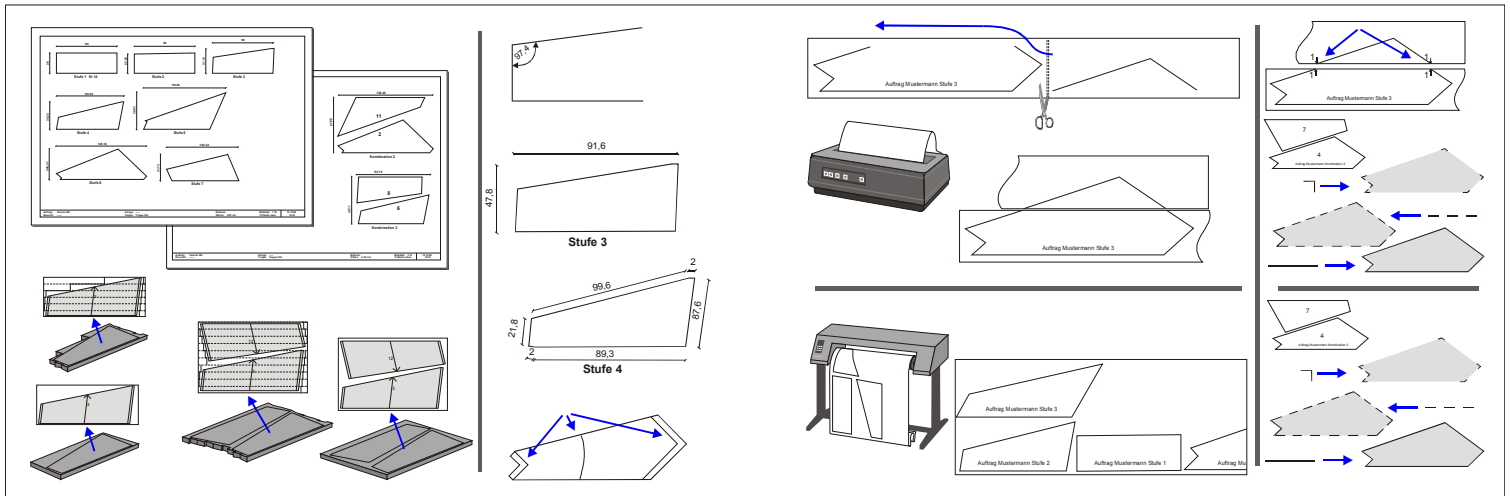

Risers / Type

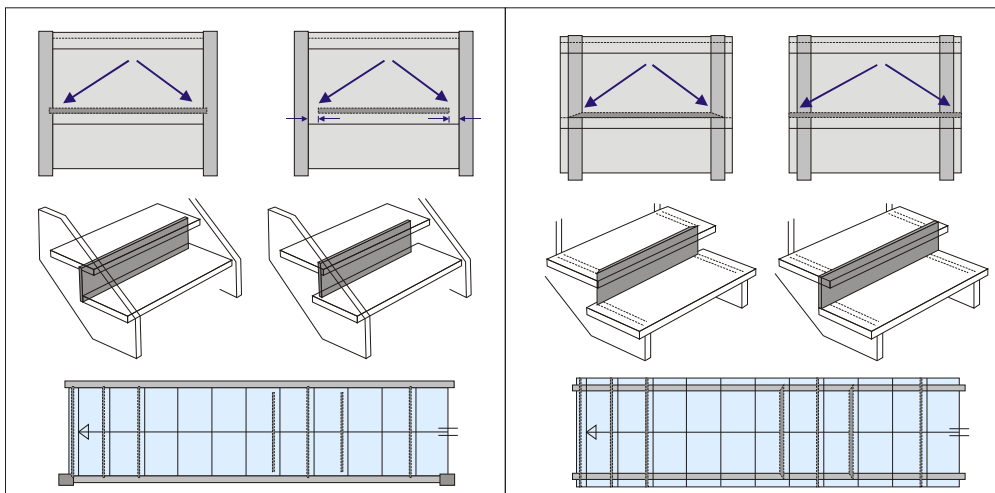

Version CAD-ND Basis

Risers / Details

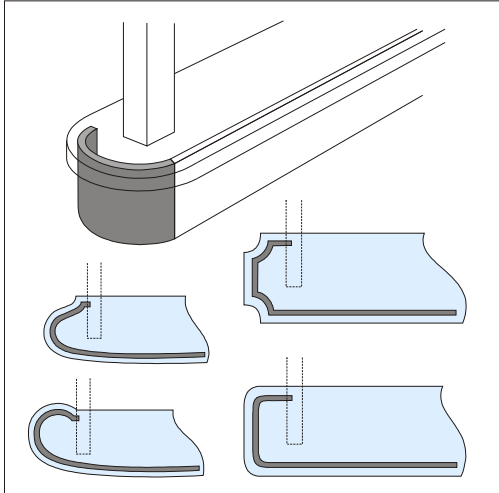

Risers / Connection

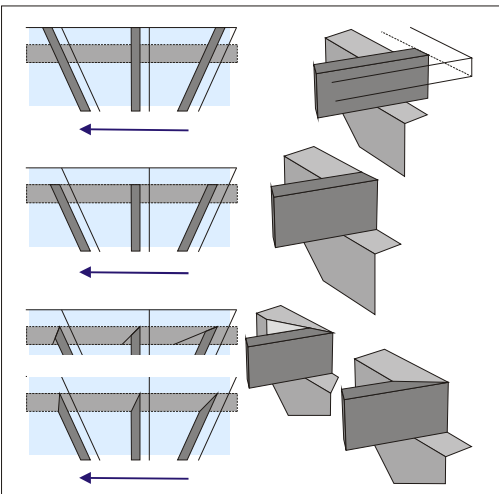
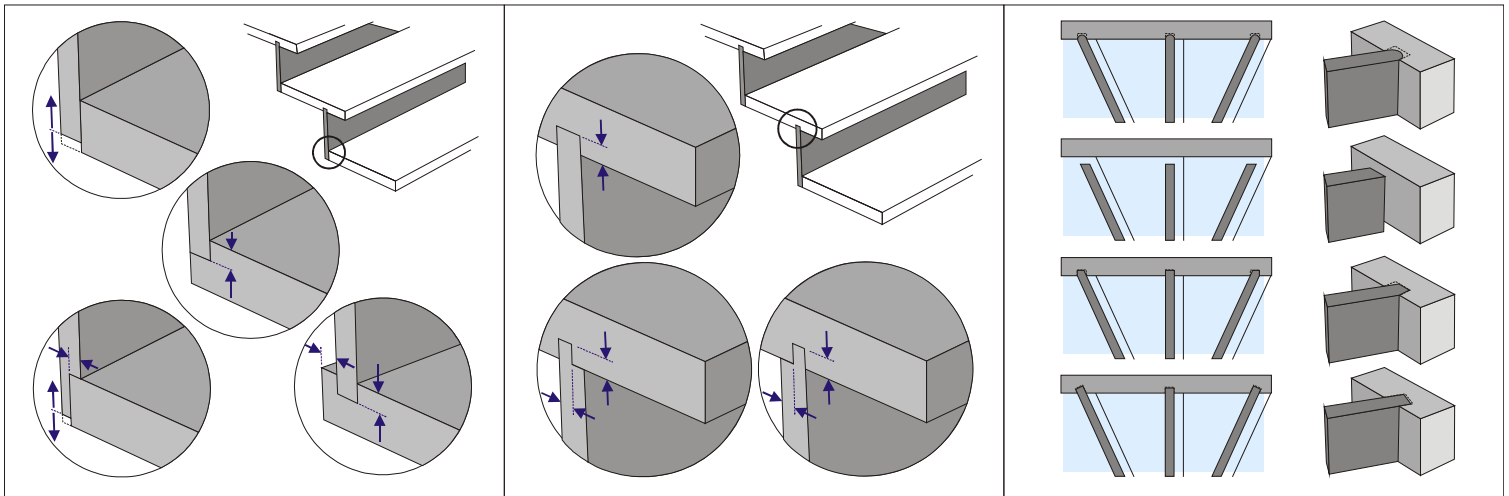

Version CAD-ND Basis

Risers / Output

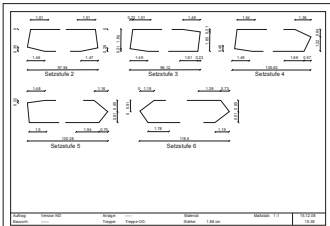

Setzstufe	Länge	Breite	Stärke	Material
	cm	cm	cm	
1	96.00	18.87	2.00	Esche
2	96.00	18.87	2.00	Esche
3	96.02	18.87	2.00	Esche
4	96.03	18.87	2.00	Esche
5	102.15	18.87	2.00	Esche
6	118.13	18.87	2.00	Esche
7	118.47	18.87	2.00	Esche
8	95.00	18.87	2.00	Esche
9	118.00	18.87	2.00	Esche
10	144.00	18.87	2.00	Esche
11	117.84	18.87	2.00	Esche
12	102.07	18.87	2.00	Esche
13	96.00	18.87	2.00	Esche
14	96.00	18.87	2.00	Esche

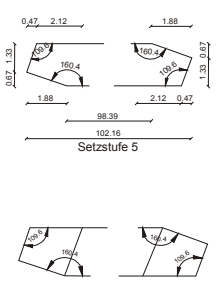

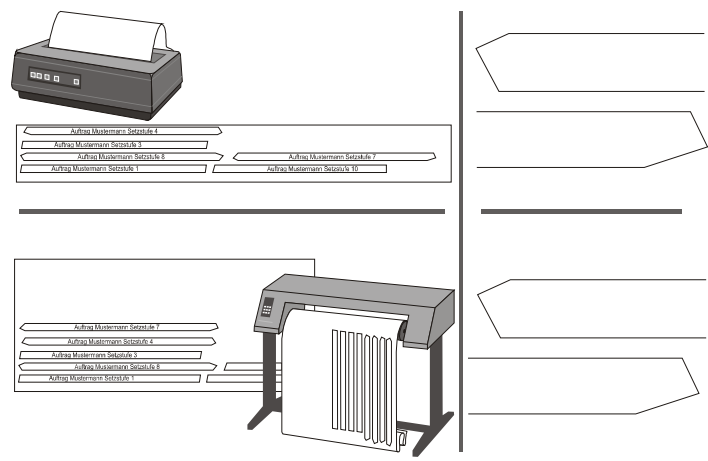

Child protection lists / Type

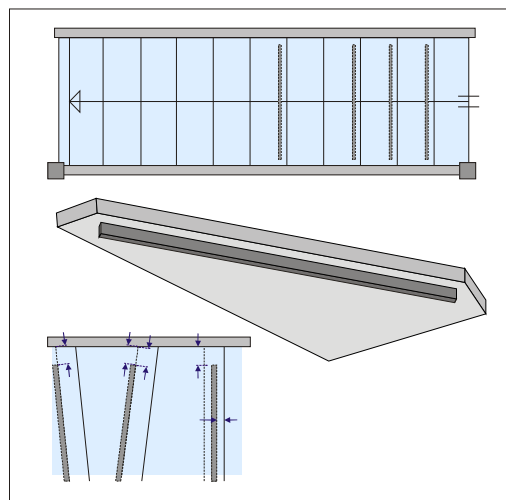

Child protection lists / Details

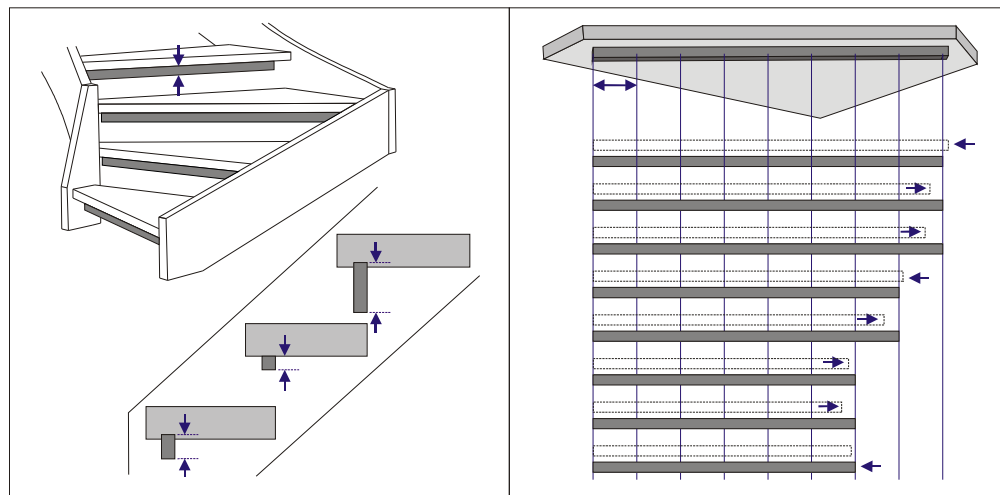

Version CAD-ND Basis

Child protection lists / Connection

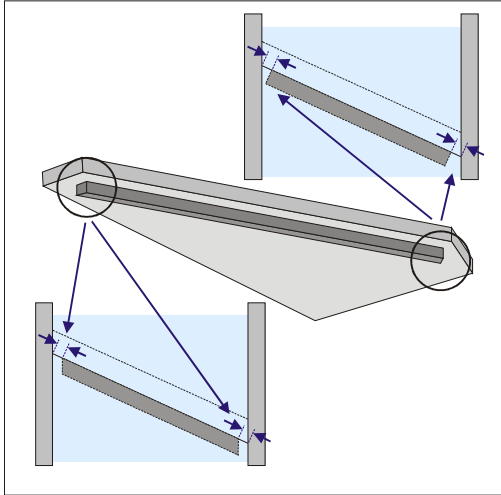

Child protection lists / Output

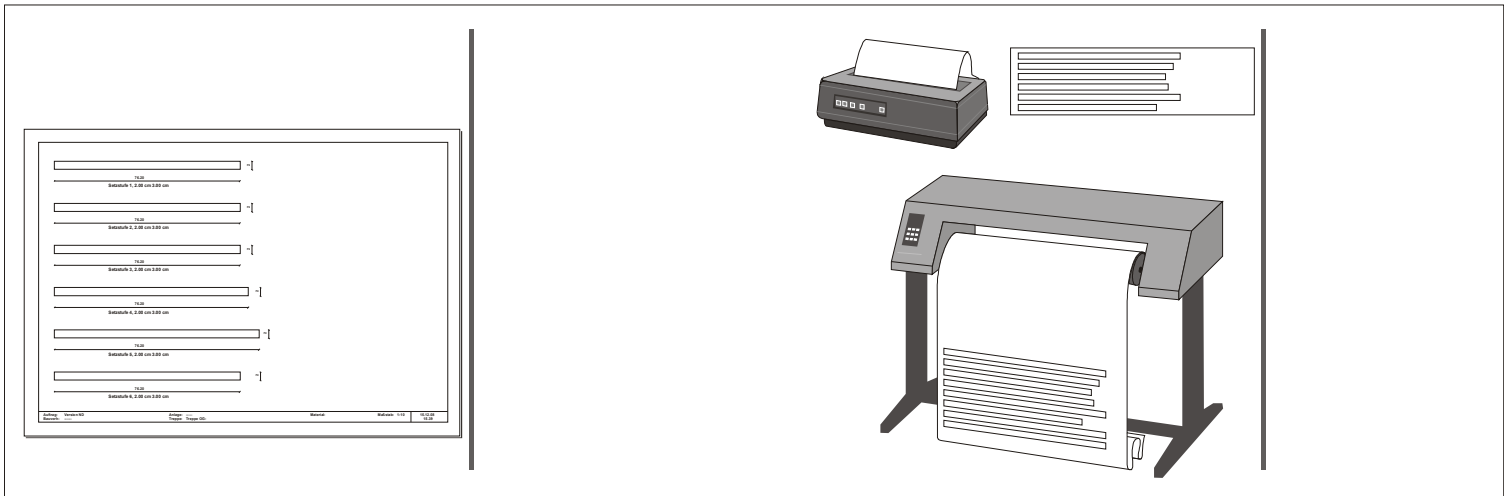

Stringers / Type

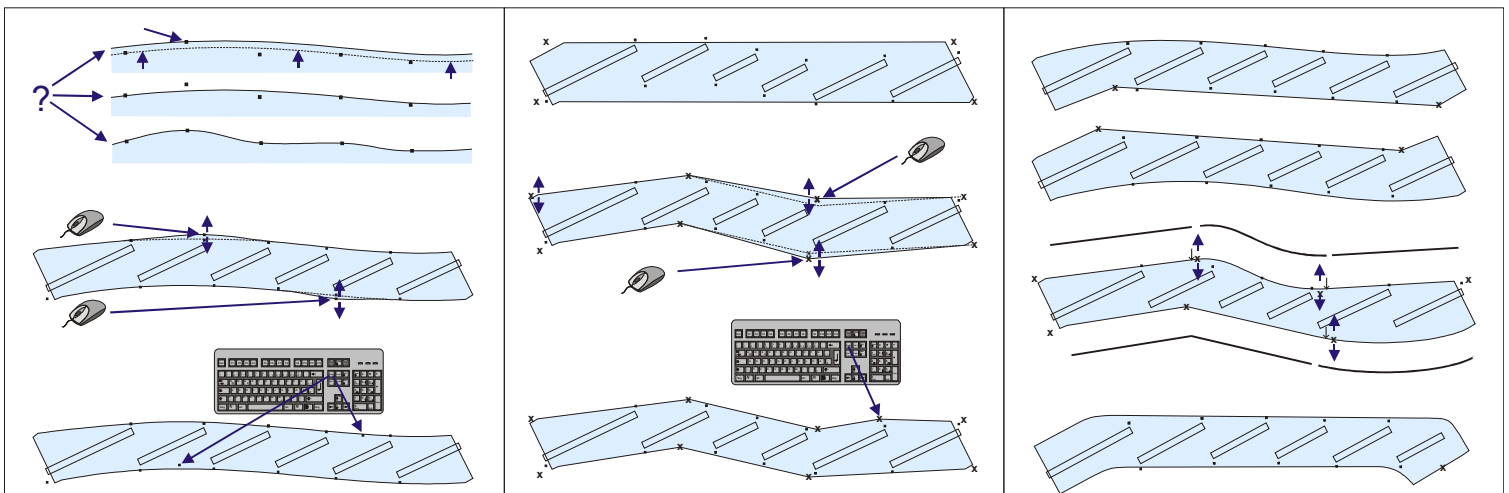

Version CAD-ND Basis

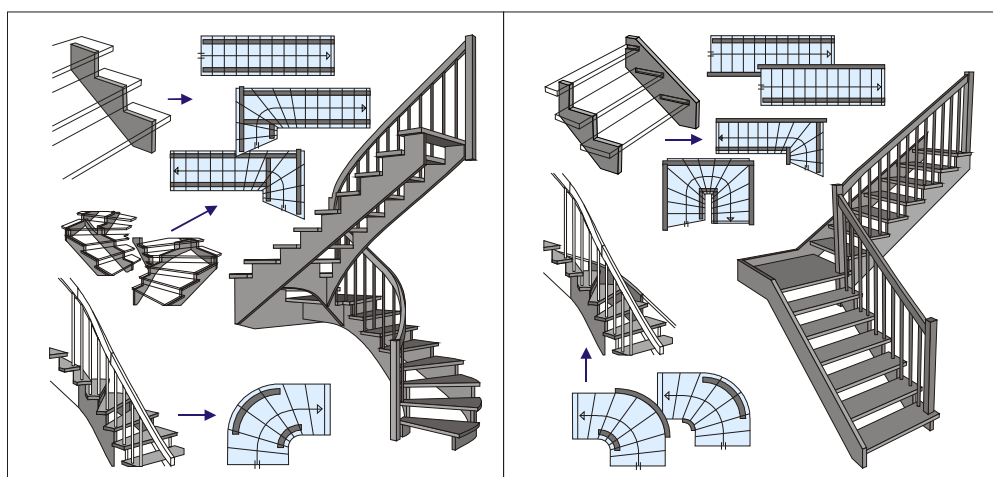
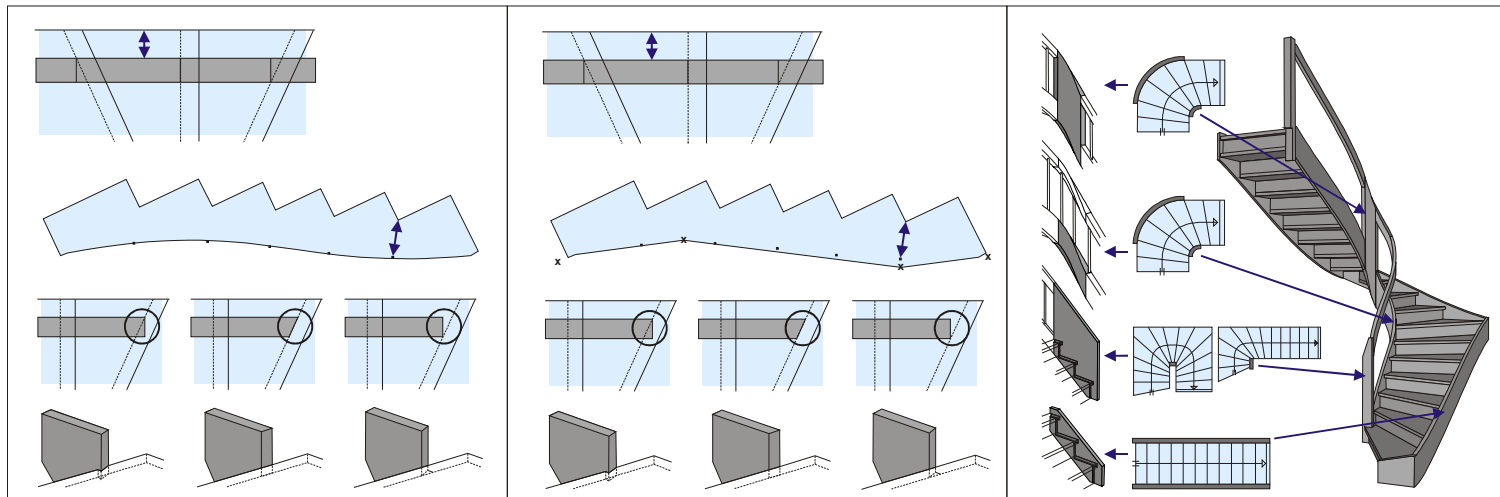

Stringers / Details

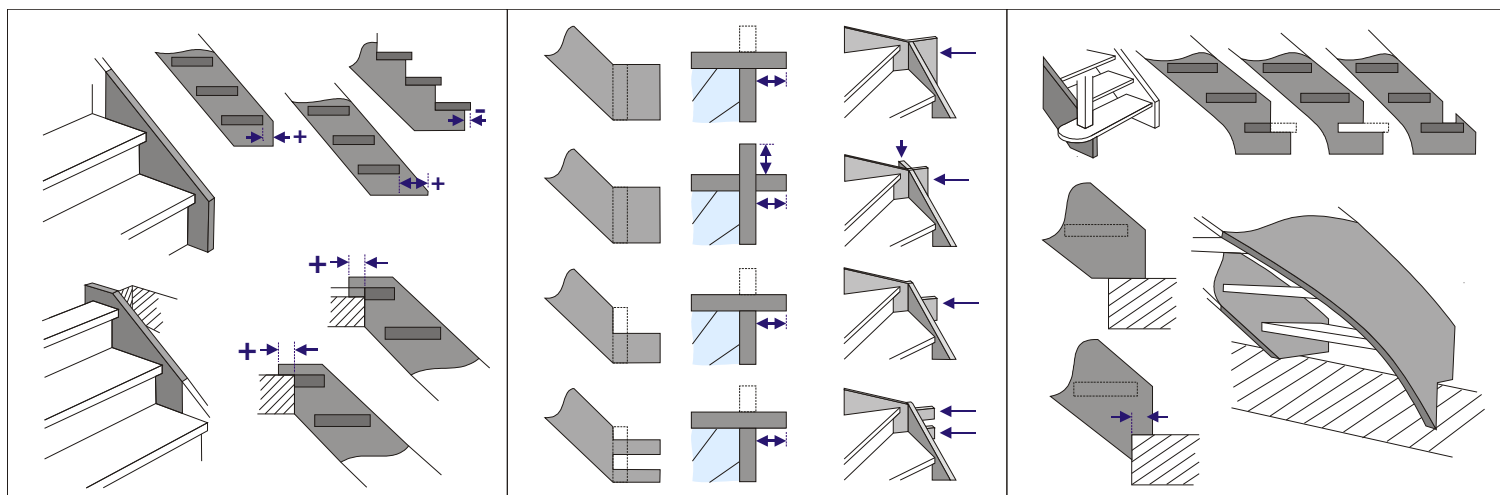

Version CAD-ND Basis

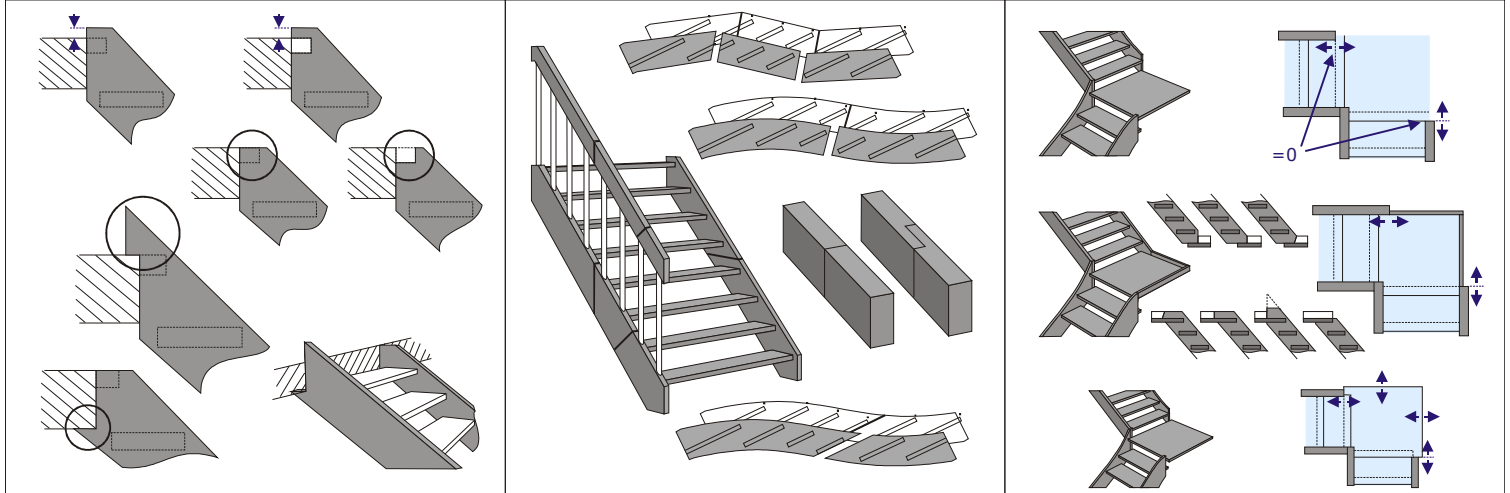

Stringers / Connection

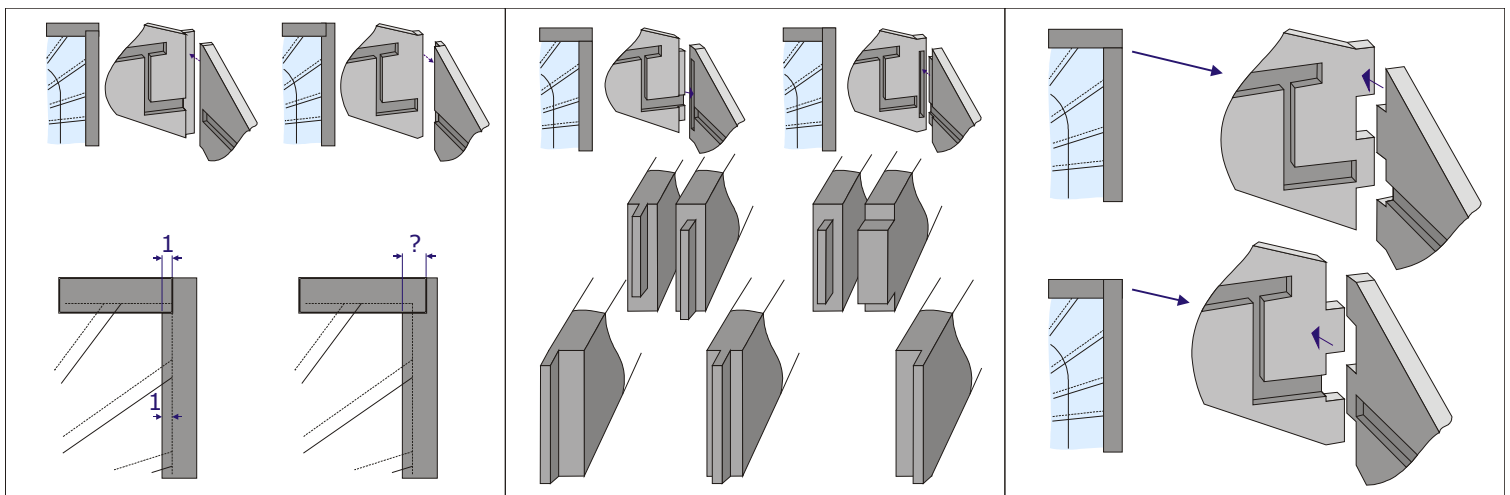
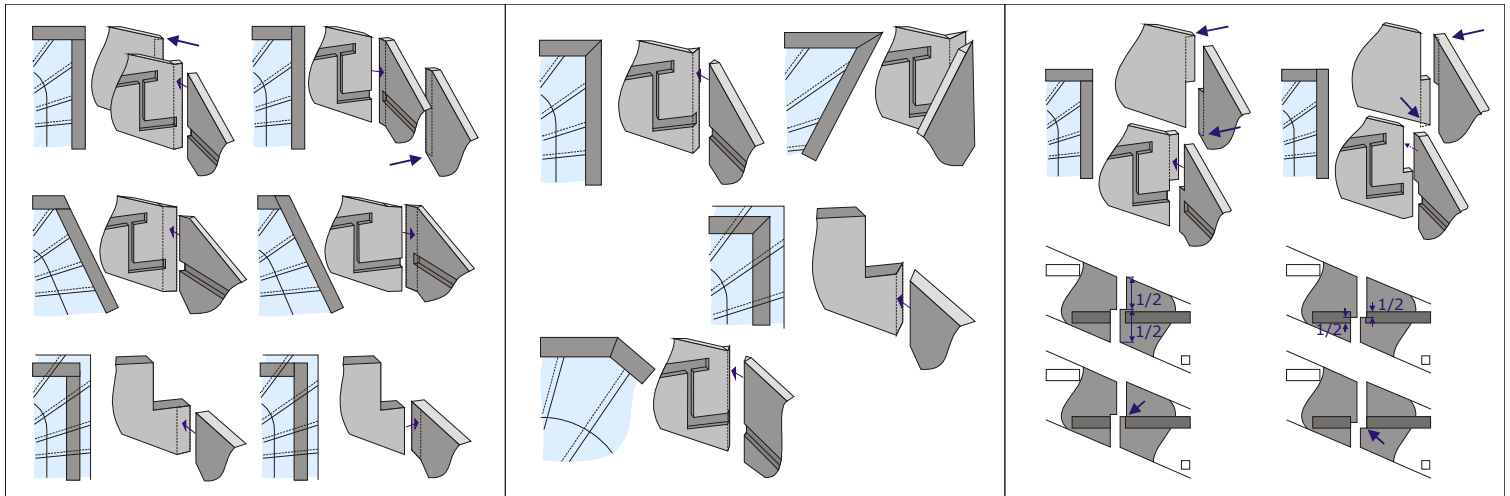

Version CAD-ND Basis

Stringers / Drillings

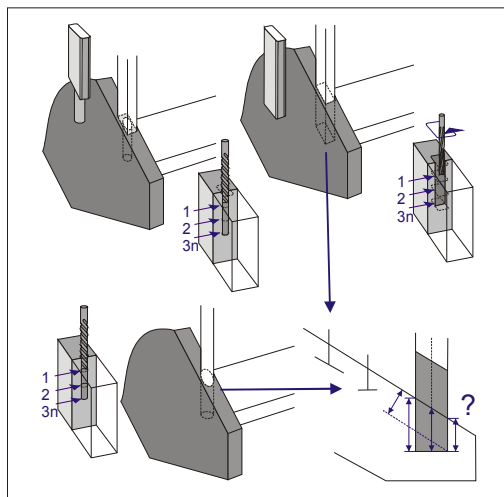

Stringers / Output

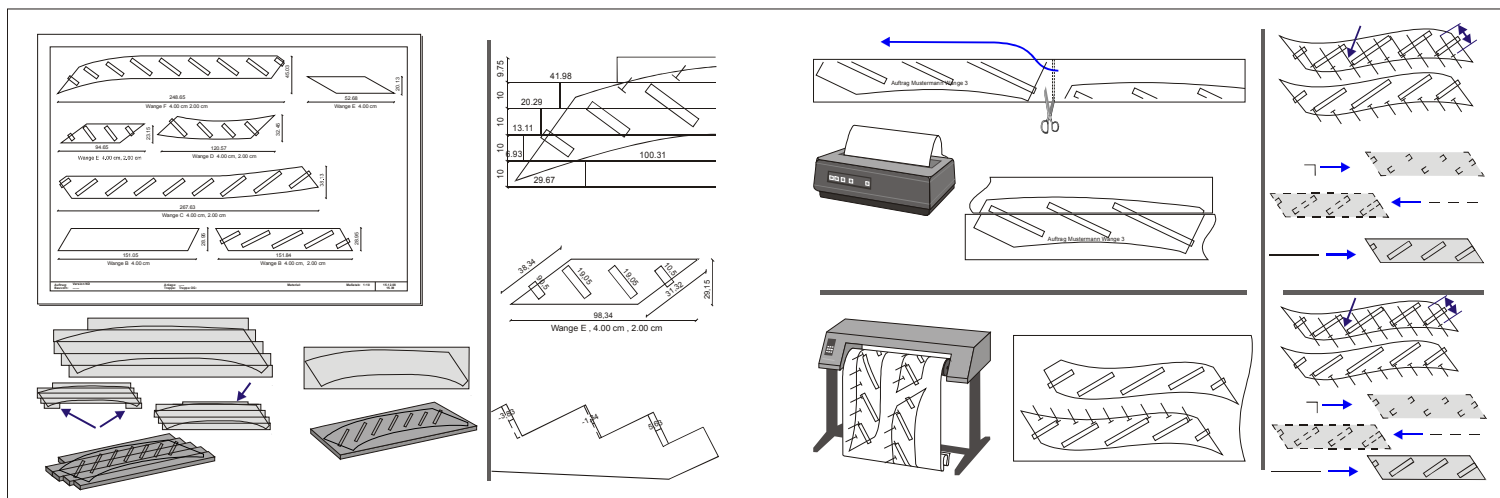

Handrails / Type

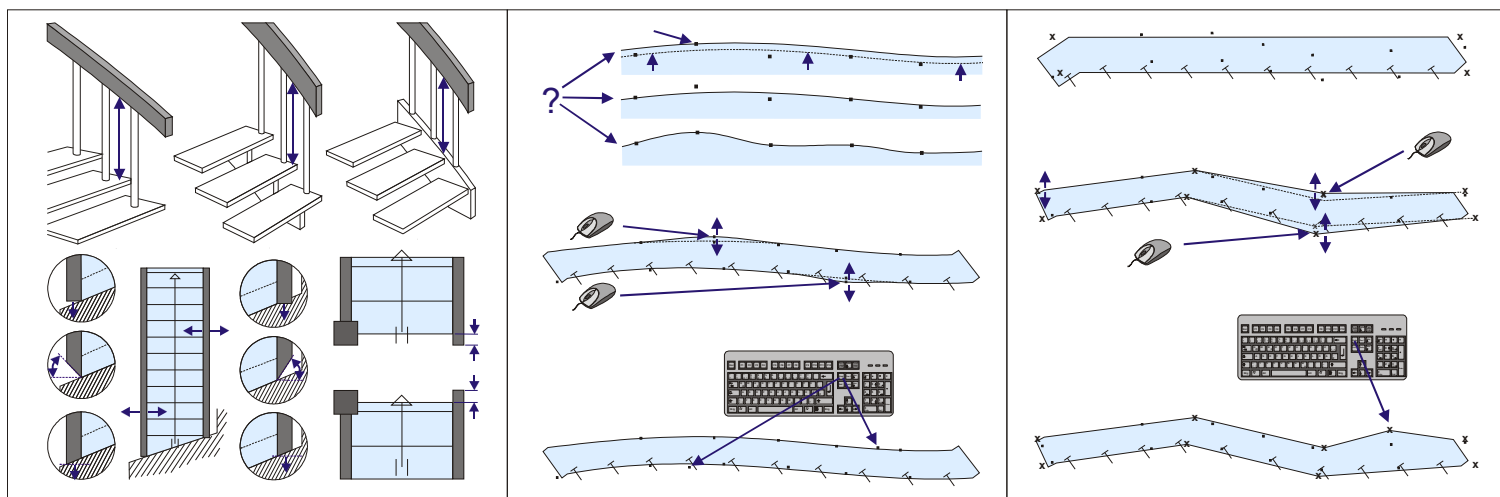

Version CAD-ND Basis

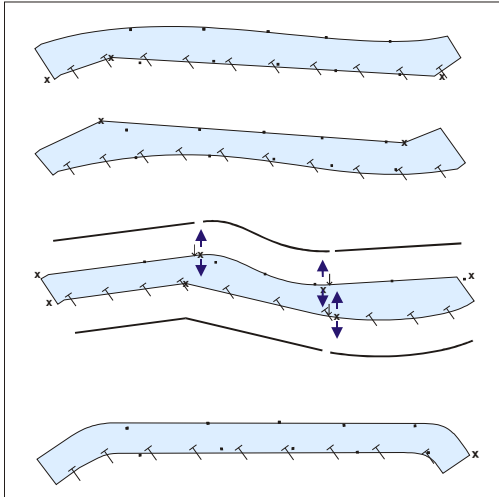

Handrails / Details

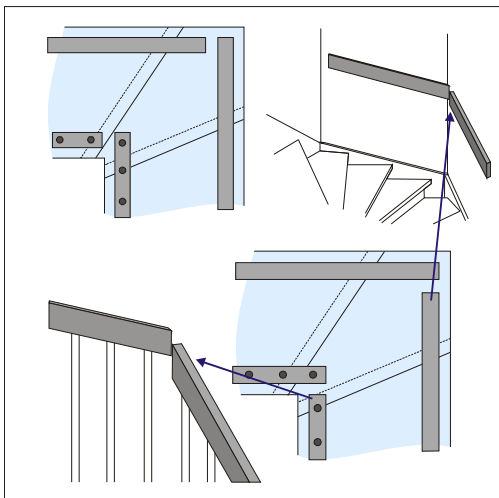

Handrails / Connection

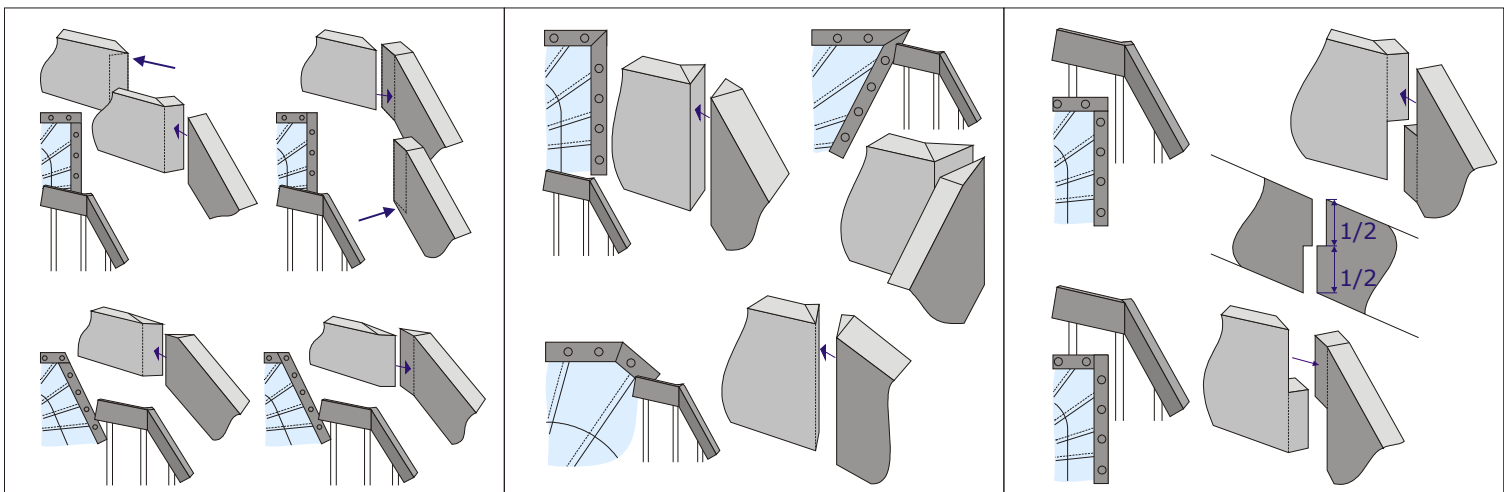

Version CAD-ND Basis

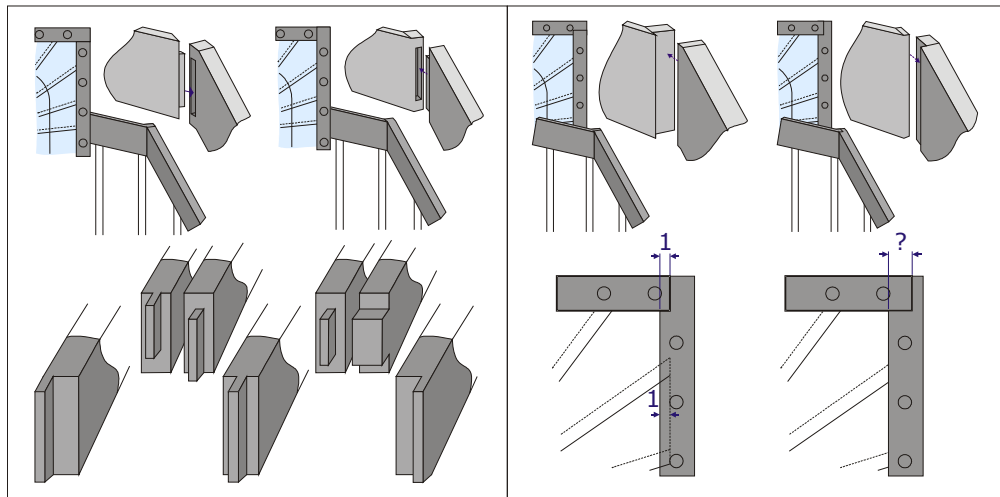

Handrails / Drillings

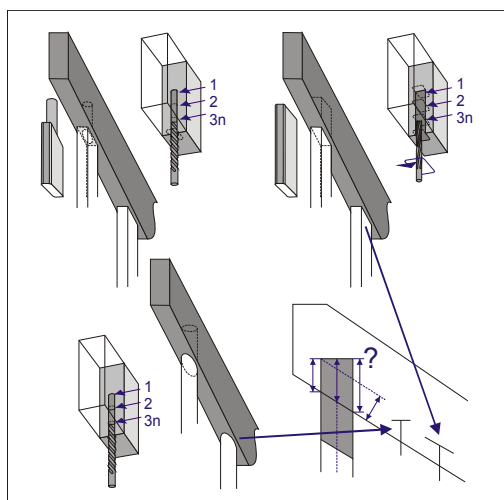

Handrails / Output

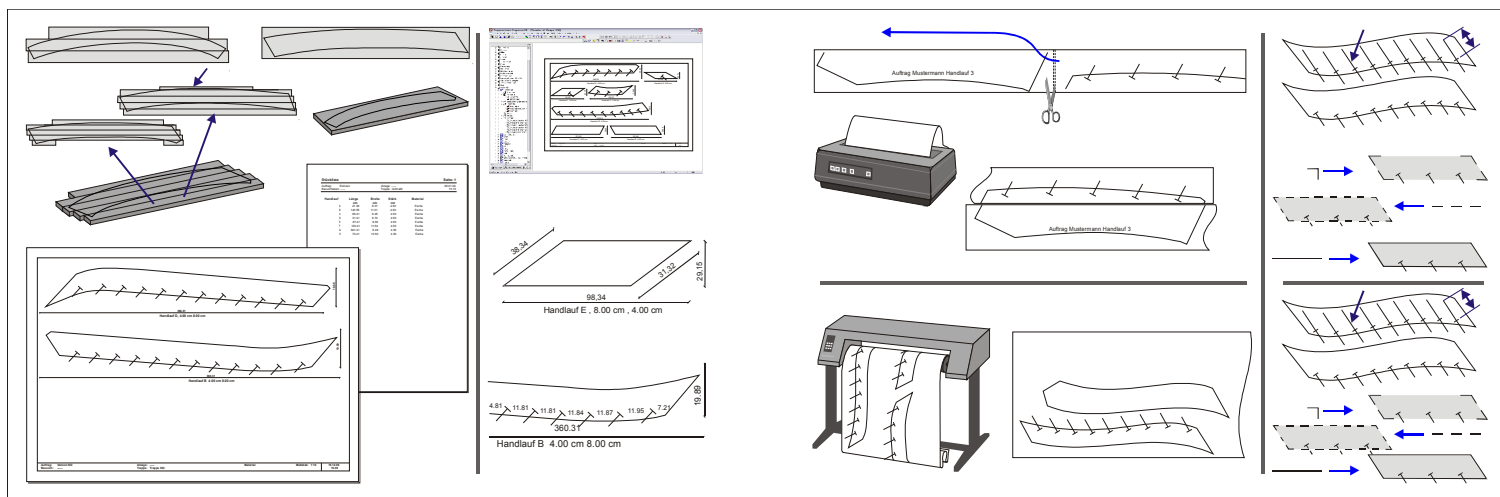

Version CAD-ND Basis

Posts / Type

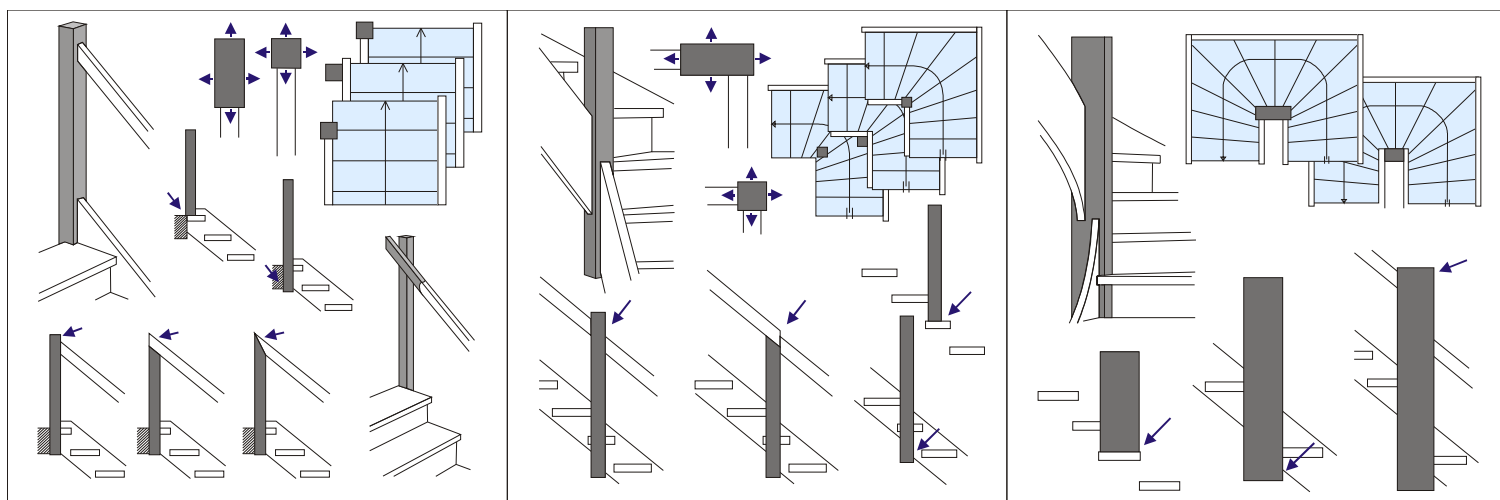
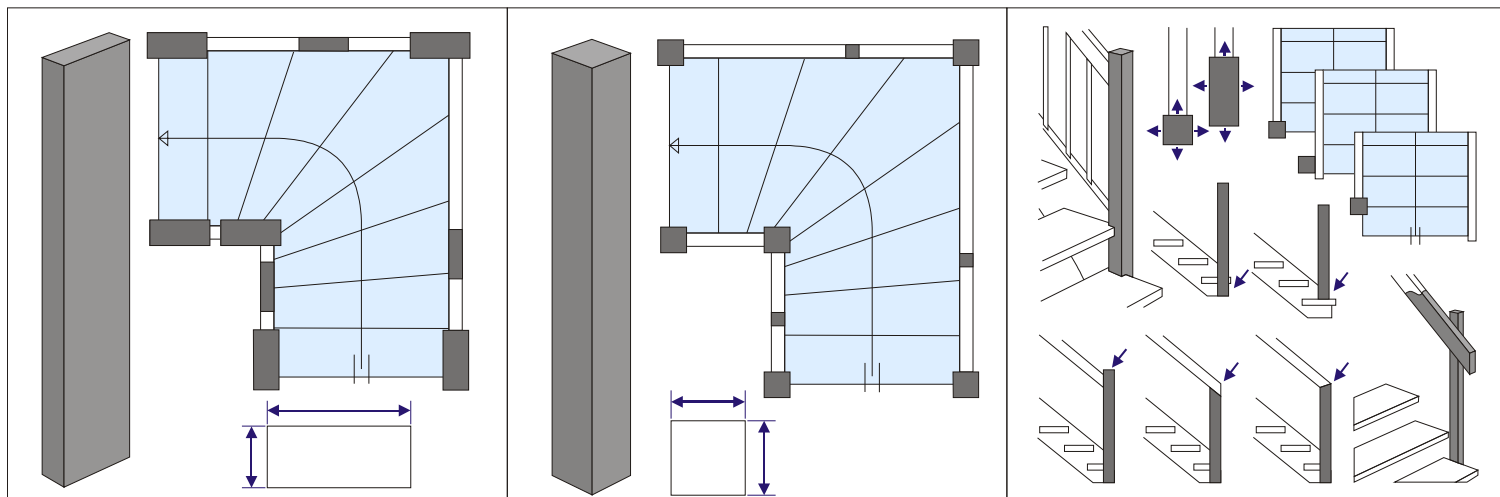

Posts / Details

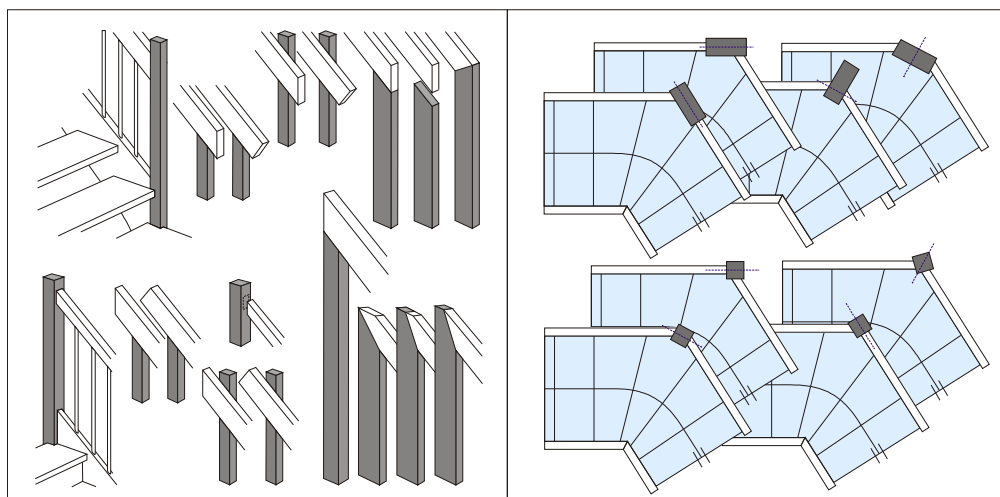

Version CAD-ND Basis

Posts / Output

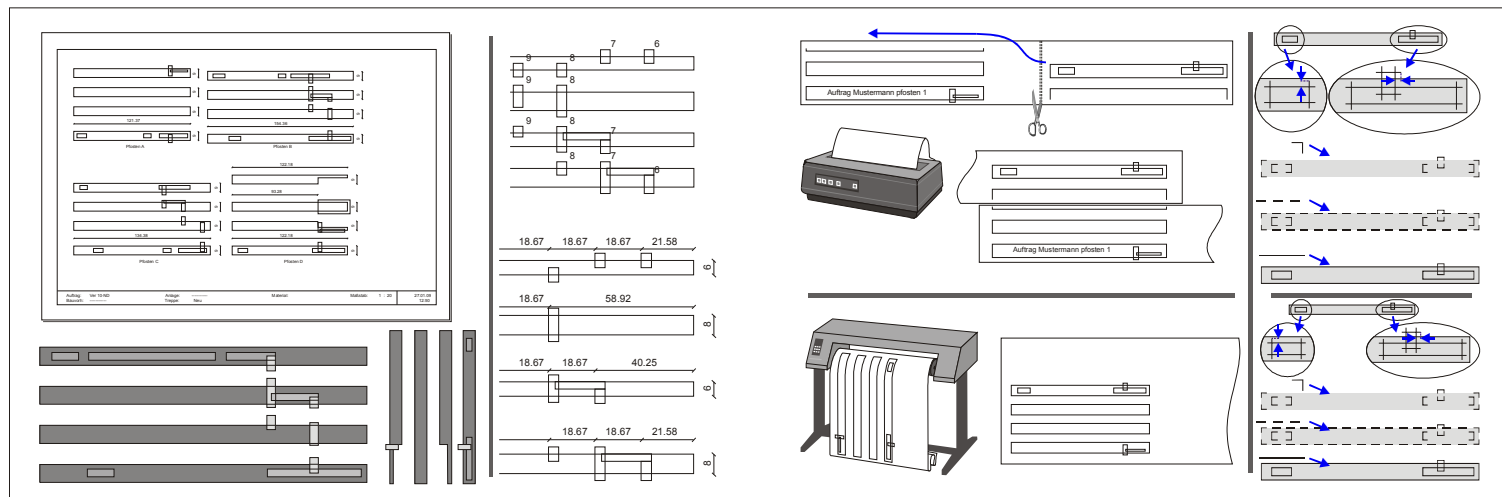

Infills / Balusters

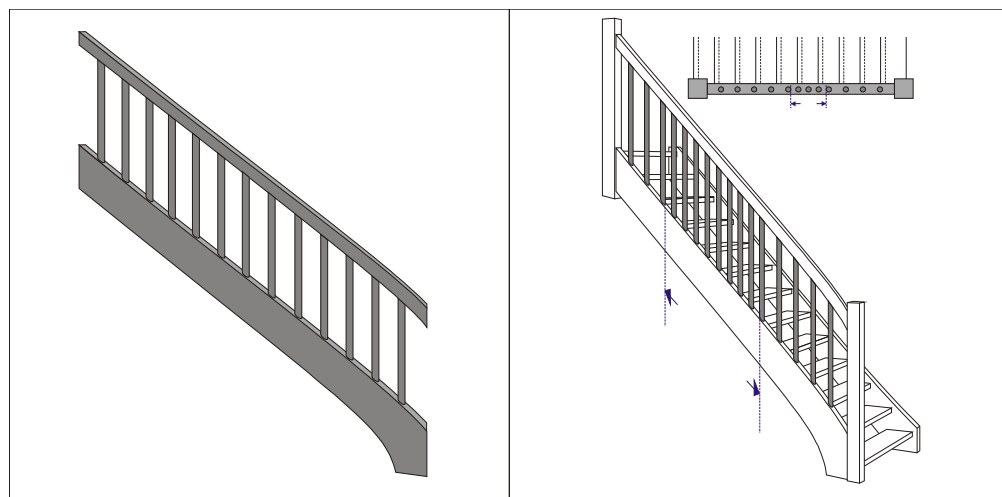
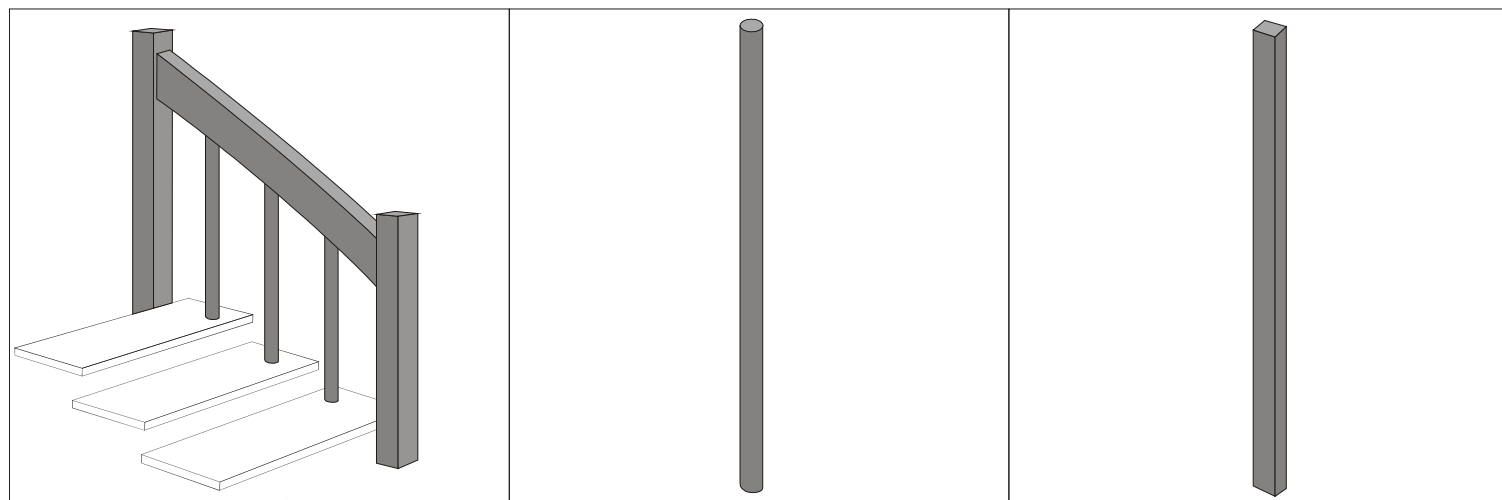



Compass Software

Software for staircase manufacturing

Version CAD-ND Basis

CAD ND Basis - TVU-No. ND0510 -

Important!

The 3D pictures shown on several pages are only given for clarity. The 3D is not part of the standard construction program and only possible with the option 3D-Plus.

Reprinting, copying or storing of this program description or parts of it on electronic data-processing devices is not allowed. A translation, however, is allowed, but only with the explicit permission of CS.

Patented names or product names in this program description may be subject to legal protection of copyright and trademarks.

Compass Software GmbH

Steinhammerstr. 140 a
44379 Dortmund

Tel.: +49 (0) 2 31 98 12 90-0
Fax: +49 (0) 2 31 98 12 90-10

Web: www.compass-software.de
Mail: mail@compass-software.de

© Compass Software GmbH 2009
All rights reserved

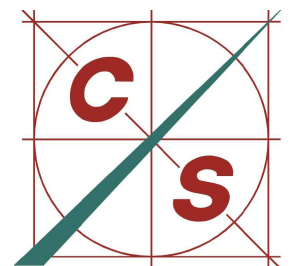

Compass Software